

ASSEMBLY INSTRUCTIONS

SKY 180

THANK YOU FOR PURCHASING THIS QUALITY PRODUCT. READ THIS INSTRUCTION CAREFULLY. SEE PART LIST AND HARDWARE LIST FOR GUIDANCE, BE SURE ALL PARTS ARE COMPLETE BEFORE YOU ASSEMBLE.

- CAUTIONS:**
1. DO NOT FULLY TIGHTEN THE BOLTS UNTIL ALL BOLTS IS READY ASSEMBLED.
 2. DO NOT OVER TIGHTEN THE BOLTS TO AVOID CAUSING DAMAGES TO THE THREAD.
 3. KEEP ALL PART AND HARDWARE OUT OF REACH OF CHILDREN.

TOOLS NEEDED : SCREWDRIVER (NOT PROVIDED)

PART LIST		
ITEM	DESCRIPTION	QTY
A	HEADBOARD	1 PC
B	FOOTBOARD	1 PC
C	SIDE RAIL	2 PCS
D	CENTER SUPPORT	2 PCS
E	CENTER SUPPORT LEG	6 PCS
F	SLAT	1 SET
G	BED LEG	4 PCS

HARDWARE LIST		
ITEM	DESCRIPTION	QTY
1	JCBC BOLT M6 x 60mm	6 PCS
2	CSK SCREW M4 x 20mm	4 PCS
3	CSK SCREW M4 x 38mm	12 PCS
4	CSK SCREW M4 x 45mm	12 PCS
5	ALLEN KEY M4	1 PC
6	ALLEN KEY M5	1 PC

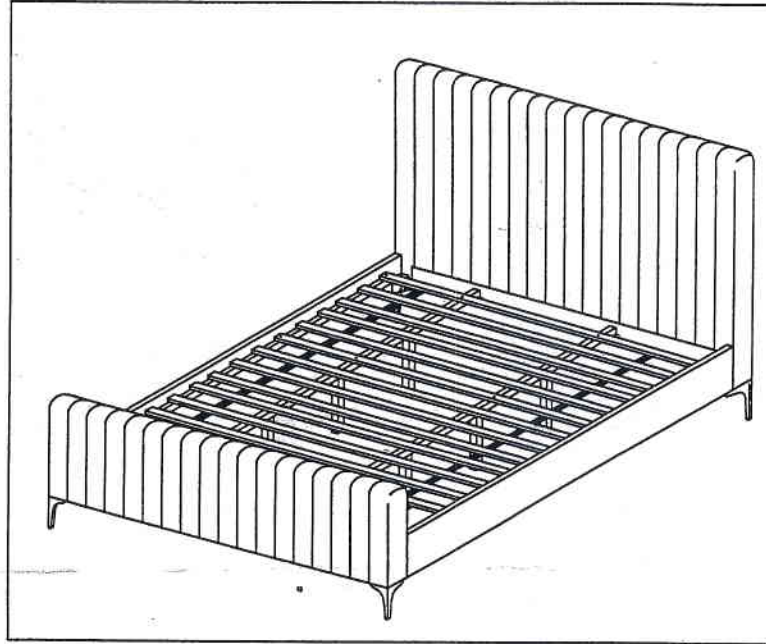

STEP 1

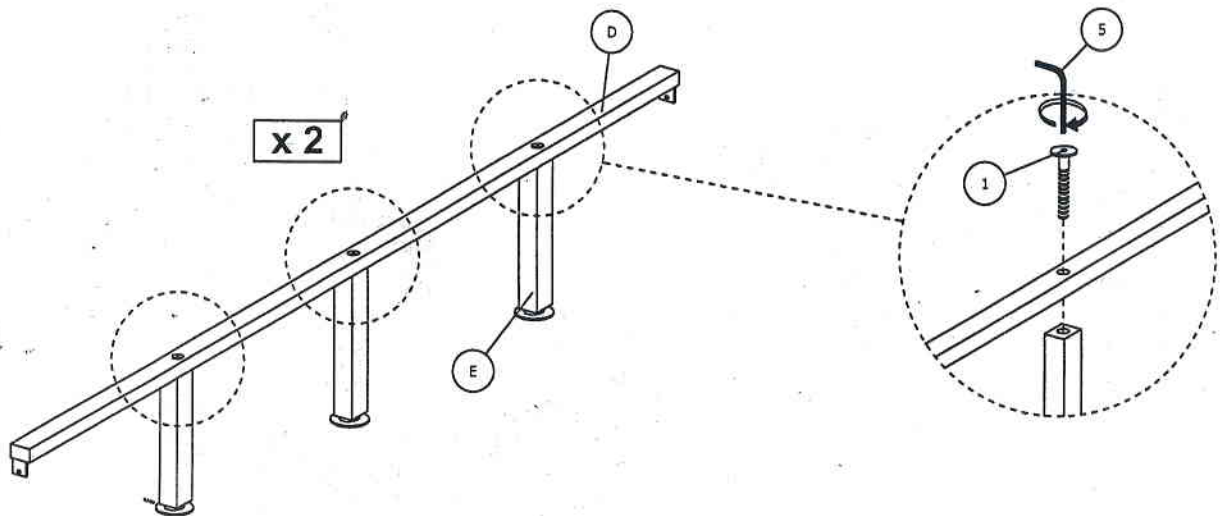

STEP 2

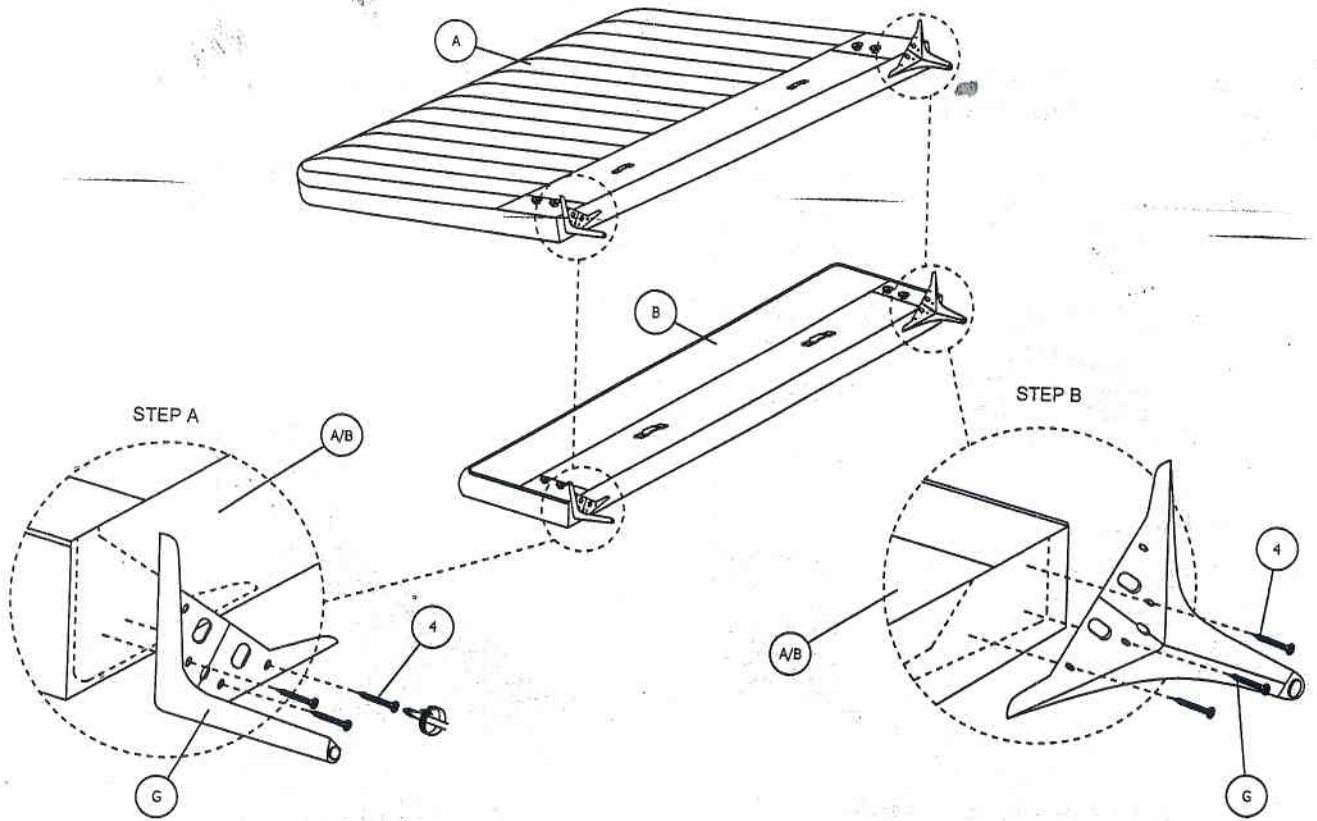

PLACE LEGS ON OUTLINE MARKINGS SHOWN ON HEADBOARD & FOOTBOARD.

STEP 3

STEP A : Use the ALLEN KEY M5 (6) to turn loose all the JCBB BOLT prefix at HEADBOARD (A) and FOOTBOARD (B) , but do not pull out.

STEP B : Tighten them after assembly the SIDE RAILS (C).

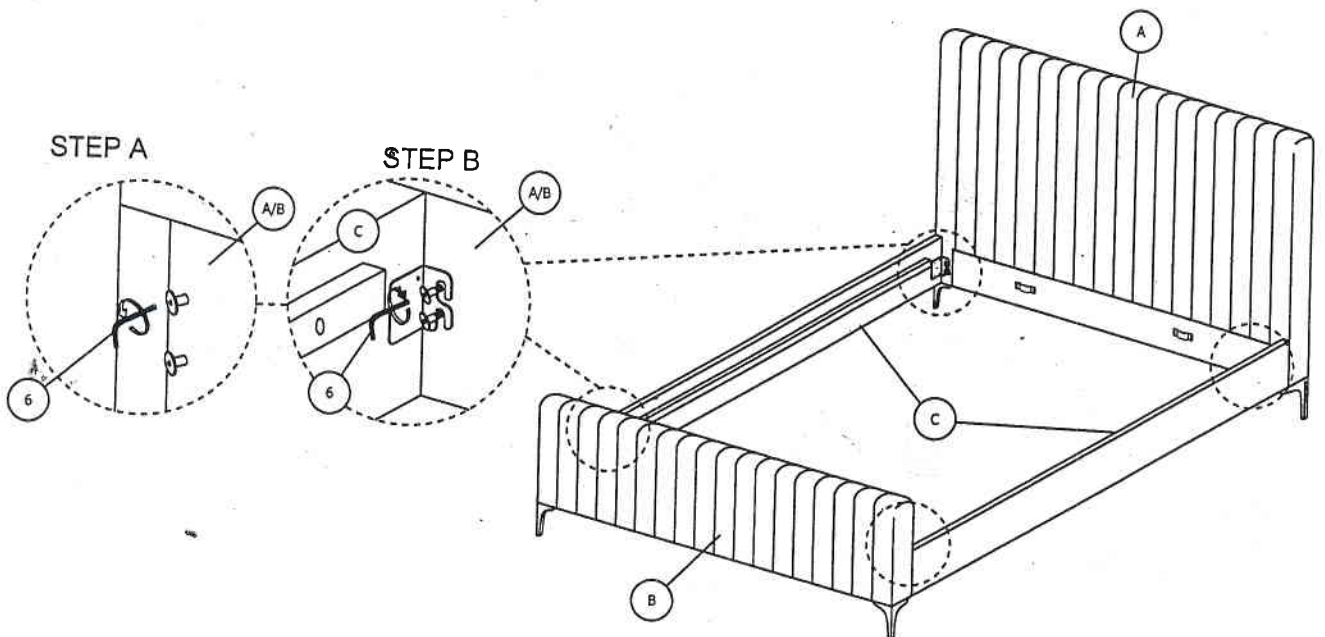

STEP 4

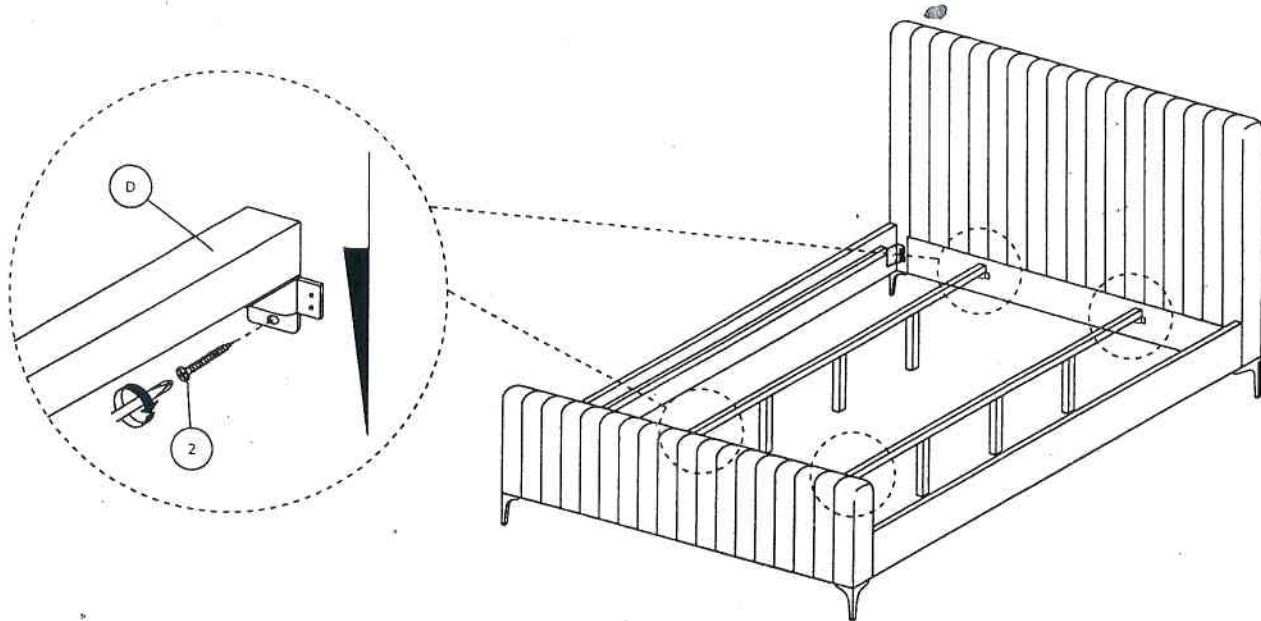

STEP 5

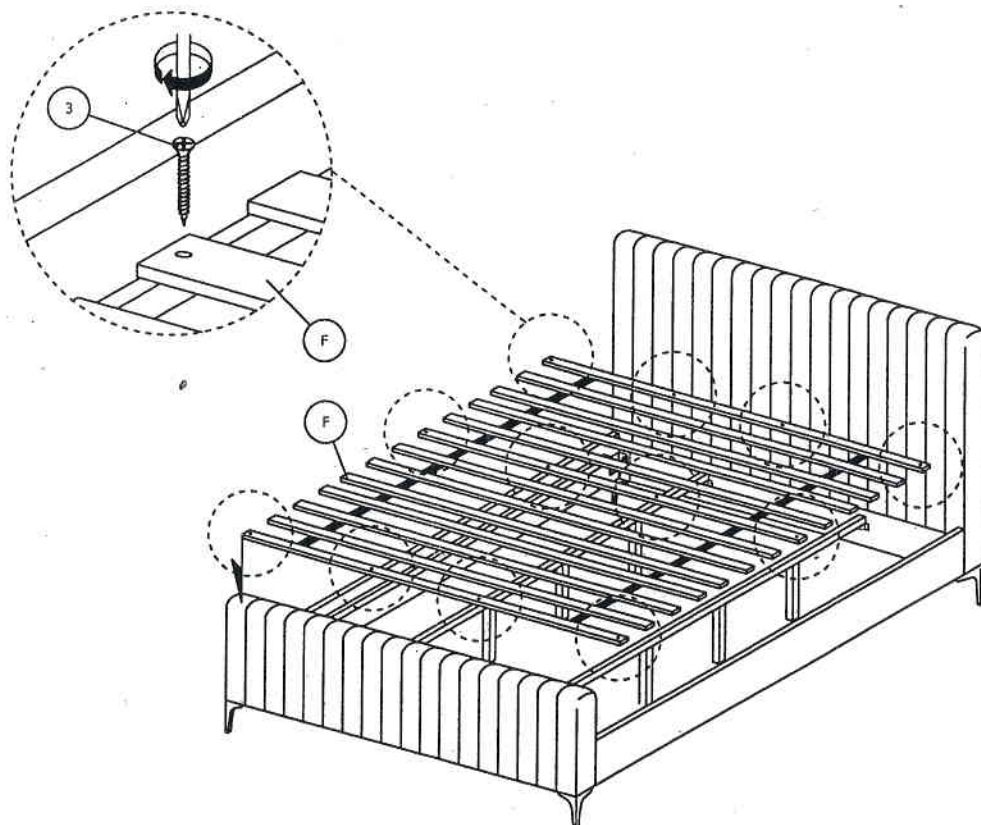

Assembly completed

* When moving bed position, the center support leg levelers must be adjust up right to avoid breakage of the leg and center suppo